

Motic[®]

**SMZ-161 Series
Stereo Zoom Microscopes
Instruction Manual**

WWW.MOTIC.COM

MOTIC INCORPORATION LTD.

We are constantly endeavoring to improve our instruments and to adapt them to the requirements of modern research techniques and testing methods. This involves modification to the mechanical structure and optical design of our instruments.

Therefore, all descriptions and illustrations in this instruction manual, including all specifications are subject to change without notice.

TABLE OF CONTENTS

Section	Page
1. INTRODUCTION	3
1.1 Nomenclature	4
2. UNPACKING AND ASSEMBLING THE MICROSCOPE	5
2.1 Unpacking the Microscope	5
2.2 Assembling the Microscope	5
3. MICROSCOPE ALIGNMENT AND OPERATION	6
3.1 Interpupillary Distance	6
3.2 Focusing the Microscope	6
3.3 Magnification and Working Distance	6
3.4 Changing the Bulb	7
4. KNOWING YOUR MICROSCOPE	8
4.1 Stereo Body with Binocular or Trinocular Head	8
4.2 Stand	9
4.3 External Illuminator	9
4.4 Eyepieces and Auxiliary Objectives	10
4.5 Other Accessories	11
5. CLEANING AND CARING FOR THE MICROSCOPE	13
5.1 Protection against Dust	13
5.2 Protection against Water and Moisture	13
5.3 Cleaning	13
5.4 Moving the Microscope	14
5.5 Electrical Parts of the Microscope	14
APPENDIX 1: SMZ-161 SPECIFICATIONS	15
APPENDIX 2: SMZ-161 OPTICAL DATA	16

1. INTRODUCTION

The **Motic** SMZ-161 series stereomicroscopes are high performance Greenough design stereomicroscopes with continuous zoom ranges of 6:1. The microscopes in this series allow continuous variable magnification between 7.5X - 45X, while total magnification varies from 2.25X to 180X depending on the eyepieces and auxiliary objectives used. With the bilateral zoom knobs, users are able to adjust magnification while the microscope remains perfectly parfocal.

The SMZ-161 is the ideal instrument for examining objects of industrial, biological, medical or educational nature.

SMZ-161 Standard Configuration and Parameters:

For detailed specifications of the SMZ-161, please refer to the Appendix 1.

Model	Lens Tubes	Eyepieces	Auxiliary Objectives	Zoom factor	Magnification	Working Distance
SMZ-161B	Binocular	WF10X (Ø20)	Optional	1:6	7.5X-45X	110mm
SMZ-161T	Trinocular					

There are two models in the series: the **SMZ-161B** which is equipped with a binocular system, and the **SMZ-161T** which is equipped with a trinocular system allowing for the attachment of CCD and digital camera devices.

1.1 Nomenclature

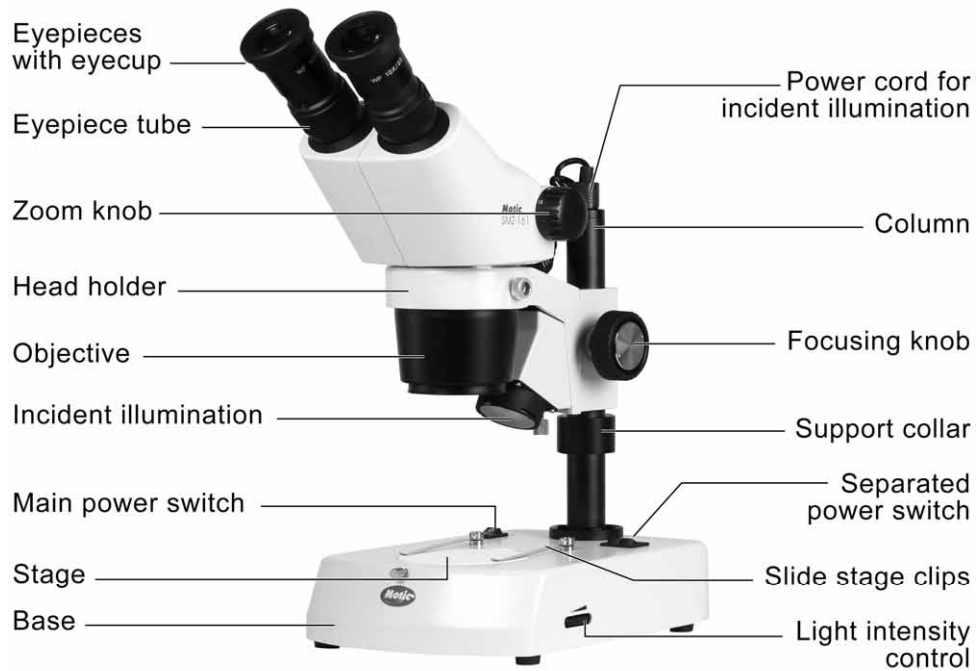

SMZ-161 R2GG / R2LED (Fig.1)

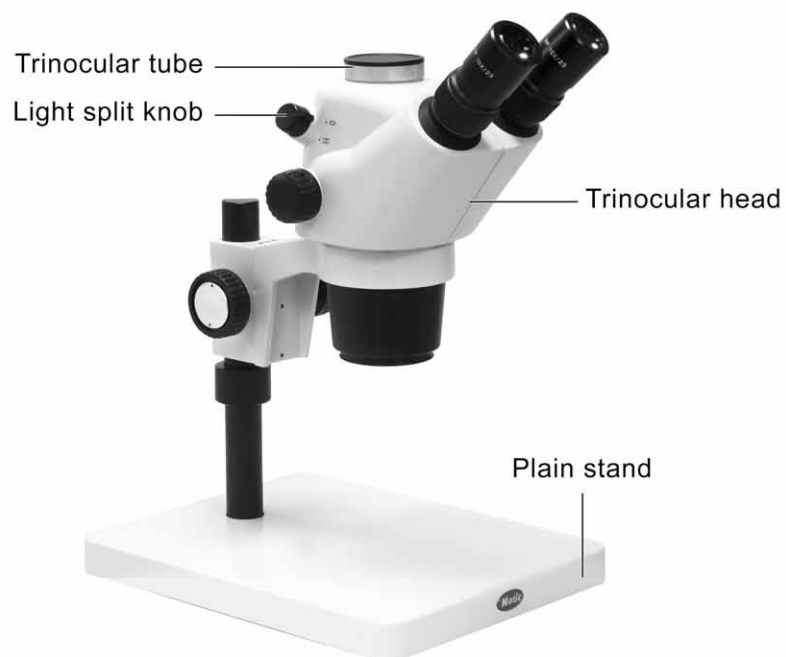

SMZ-161 TP (Fig.2)

2. UNPACKING AND ASSEMBLING THE MICROSCOPE

2.1 Unpacking the Microscope

The components for SMZ-161 stereomicroscopes are shipped integrative for protection. Open the styrofoam packing with care and do not leave any components attached to the packing being removed. Do not discard any of the packing materials until all of the components have been identified. If any damage occurs during transit, contact both the carrier and your supplier immediately.

2.2 Assembling the Microscope

- 2.2.1 When handling the components, especially the optical parts, avoid touching any lens surfaces with bare hands or fingers as fingerprints and grease stains affect image quality.
- 2.2.2 After unpacking the stand, put it on a stable and flat table. Loosen the locking screw of the head holder, adjust the height of the head holder and lock the locking screw again. Make sure that the support collar is secured firmly below the head holder along the vertical post. This is important as this collar keeps the microscope from sliding down the column.
- 2.2.3 The head holder should rest on the support collar and both the head holder locking screw and the collar locking screw should be tightened.
- 2.2.4 Put the stereo body onto the head holder and lock it using the locking screw located on the right hand side of the head holder. To maintain the best stability, you are advised to lock the screw on the left hand side of the head holder as well.
- 2.2.5 After removing the wrapping papers and packing materials around the eyepieces and other optical parts (avoid touching the lens surfaces), carefully place the eyepieces into the eyepiece tubes and secure them using the locking screws. If necessary, loosen the locking screws before putting in the eyepieces.
- 2.2.6 Before turning on the power, plug the illumination power cord into the socket at the top of the column. Next, plug the power cord of the main frame into the local power supply. **Note: before plugging in and turning on the power, make sure that the operation voltage of the microscope matches the voltage of the local power supply.**

3. MICROSCOPE ALIGNMENT AND OPERATION

3.1 Interpupillary Distance

Adjust the two eyepiece tubes until only one circular field can be seen through the two eyepieces. If two separate circles appear, the interpupillary distance is too large; if two overlapping circles appear, the interpupillary distance is too small.

3.2 Focusing the Microscope

To focus the sample, use the focusing knobs located on both sides of the head holder. By turning these knobs, the microscope can be moved up or down a certain distance to focus the sample. This movement is enabled by a “**rack and pinion**” mechanism. The tension of the focusing knob can be adjusted using the tension knob located in the inner region of the focusing knob on the right.

If a sharp focus cannot be achieved using this knob, release the locking screw and support collar and move the whole microscope up or down.

3.2.1 Using the focusing knob, focus the sample using the highest magnification strength. If the sample cannot be brought into focus, adjust the height of the microscope along the column. Remember to tighten the locking screw and support collar after adjusting the height of the microscope.

3.2.2 Turn the zoom to the highest magnification. Adjust the focusing knob until a clear and sharp image is obtained.

3.2.3 Turn the zoom to the lowest magnification. Adjust the right eyepiece diopter until the image seen through the right eyepiece is clear and sharp.

3.2.4 Repeat the procedure for the left eyepiece. Next, check the image focus for the entire zoom range; it should now be perfectly parfocal.

3.3 Magnification and Working Distance

3.3.1 Select the desired magnification strength by adjusting the zoom knob. Change the optional eyepieces and/ or add an optional auxiliary objective, for other range of magnification.

3.3.2 Total magnification used can be calculated using the following equation:

$$\text{Total magnification} = \text{Eyepiece magnification} \times \text{Zoom magnification} \times \text{Objective lens magnification}$$

3.3.3 Working distance varies from 301mm (when using a 0.3X objective lens) to 38.6mm (when a 2X objective lens is used). Normal working distance for standard configuration (1X objective lens) is 110mm.

3.4 Changing the Bulb

3.4.1 Before changing the light bulb, make sure that the power is switched off and the power cord has been disconnected from the main power supply.

3.4.2 For incident light, unscrew the lamp collector piece, remove the old halogen bulb (when a R2GG halogen stand used) or the old LED module (when a R2LED stand used) from the socket and carefully plug in the new halogen bulb or LED module. Screw the collector piece back in after changing the old one.

3.4.3 For transmitted light, turn the microscope over so that the bottom plate of the stand faces towards the user. Remove the bottom plate by unscrewing the four rubber feet. For R2GG halogen stand, remove the old light bulb from the socket and carefully plug the new light bulb in; for R2LED stand, unscrew the plank and remove the old LED module and screw the new LED module in place. Finally, firmly secure the bottom plate after changing the light bulb or LED module.

3.4.4 Never touch the glass surface of the light bulb with bare hands. Any grease on the light bulb will affect heat dissipation, greatly shortening the life span of the light bulb. If the surface of the bulb has been accidentally touched, clean with alcohol and tissue.

4. KNOWING YOUR MICROSCOPE

4.1 Stereo Body with Binocular or Trinocular Head

For the SMZ-161 stereomicroscopes, the binocular or trinocular tubes are built into the stereo body to form a single unit called a “**Stereo-head**”. The SMZ-161 B (Fig.1) is equipped with a binocular tube while the SMZ-161 T (Fig.2) is equipped with a trinocular tube.

4.1.1 Stereo Body

- The Stereo body is the key component of the microscope. It includes the Greenough stereo-zoom system with a continuous zoom range of 6:1. It also includes separate left and right non-telescopic optics systems.
- With this system, users are able to enjoy excellent depth of field and stereo effects. With the help of precision optics from **Motic**, perfect parfocality is maintained throughout the entire zoom range.
- The zoom knobs are located on both sides of the microscope and scales are printed on the knobs to display the current magnification. Adjust these knobs to change the magnification of the image. If the microscope has been properly adjusted, the image should remain in focus even when the magnification is changed (parfocal). For adjustment procedures, refer to section **3.2** of this manual.
- The stereo body is mounted onto the circular mount of the head holder and is locked into place using the locking screw on the right hand side of the holder. While operating the microscope, this locking screw should always be locked to maintain utmost stability.

4.1.2 Binocular tube for the SMZ-161B

- The interpupillary distance can be adjusted by moving the two eyepiece tubes horizontally. For proper interpupillary distance adjustment, refer to section **3.1** of this manual.
- The eyepiece can be secured in the eyepiece tube using a small screw. This is important for easy adjustment of the eyepiece diopter.

4.1.3 Trinocular tube for the SMZ-161T

- The procedures for adjusting the interpupillary distance and securing the eyepieces are the same for the trinocular tube as they are for the binocular tube.
- By turning the knob at the left side of the trinocular tube, all the light from the right eyepiece tube will be deflected into the phototube for the attached imaging device.
- At the top of the trinocular tube, there is a locking screw that is used to secure the adapter for the imaging device. After fitting the adapter, this locking screw should be tightened.

4.2 Stand

Three different stands are available for the SMZ-161:

4.2.1 R2GG (Fig.1)

- New stand with reflector design to reach more homogeneous illumination and lower temperature.
- The head holder can be moved freely along the vertical post and be removed totally from the stand. The diameter of the post is 25mm.
- This stand is installed with built-in transmitted light (halogen 12V/20W) and incident light (halogen 12V/10W) illuminators.
- To turn the stand power on, the main switch (located on the left hand side) should be switched to the “on” position.
- A separated power switch for transmitted and incident illumination is located on the right hand side. Users are able to select transmitted or incident light or both with these two power switches.
- Light intensity can be adjusted by turning the knob at the bottom of the stand on the right hand side. This knob governs the light intensity for the transmitted and incident lights.
- The illuminating angle of the incident light can be adjusted using the screw located behind the illuminator.
- Besides the black and the white stage plate, a frosted glass stage plate is provided for transmitted light. This plate can be secured using the screw at the bottom front of the stand.

4.2.2 R2LED (Fig.1)

- Basically the same as the “**R2GG**” stand except that a 3W LED is used instead of halogen bulb for transmitted light and incident light. It delivers almost no heat to the sample and is ideal for biological and heat-sensitive specimen applications.

4.2.3 Plain stand (Fig.2)

- This industrial stand allows for extreme flexibility in positioning. It includes a heavy base to maintain good stability.

4.3 External Illuminator

- 4.3.1 All kinds of external illuminators can be used as incident illuminators ranging from simple desk lamps to specialized ring illuminators.

4.3.2 A specially designed cold light source employing a 12V/150W halogen illuminator is recommended as a light source. Such a light source allows users to bend and twist the arm in any direction in order to achieve the best possible illumination. As well, with a cold light source, no heat is transmitted to the specimen making it ideal for use in biological research and anatomy.

4.3.3 A 3W LED ring light illuminator for Motic SMZ-161 stereomicroscopes also is available.

4.4 Eyepieces and Auxiliary Objectives

4.4.1 There are eyepieces of different magnifications to choose from including 10X, 15X and 20X. Standard configuration is a pair of 10X eyepieces.

4.4.2 To change the eyepieces, unscrew the locking screw, remove the original eyepieces, replace with the new pair of eyepieces and secure the eyepieces using the locking screw.

4.4.3 There are additional auxiliary objectives of different magnifications to choose from including 0.3X, 0.5X, 0.63X, 0.75X, 1.5X and 2X (Fig.3). Users are recommended to select additional objectives according to working distance and magnification requirements. Please refer to the appendix (I) for details.



(Fig.3)

4.4.4 To add an additional objective to the microscope, screw it onto the bottom part of the stereo-head. The height of the microscope must be re-adjusted as the working distance will change when an additional objective is attached.

4.5 Other Accessories

4.5.1 For the SMZ-161 there are various accessories designed for various applications:

Darkfield Condenser

- Must be used with transmitted light.
- By putting this accessory onto the transmitted light outlet (with the frosted glass or stage plate removed) a darkfield effect is created.
- It is especially useful for analyzing jewelry and special techniques in Bio-Med applications including **“In-situ silver gain staining”** and embryo observation.

Polarizing kit

- Must be used with transmitted light.
- This kit (including both a polarizer and analyzer) is also placed onto the transmitted light outlet (with the stage plate removed). The sample can be placed between the polarizer and analyzer to perform polarized light microscopy.
- Useful for analyzing jewelry and the study of sectioned rock and synthetic fibers.

Jewelry Clamp (Fig.4)

- Designed to hold gems or jewelry under the microscope while performing observation.

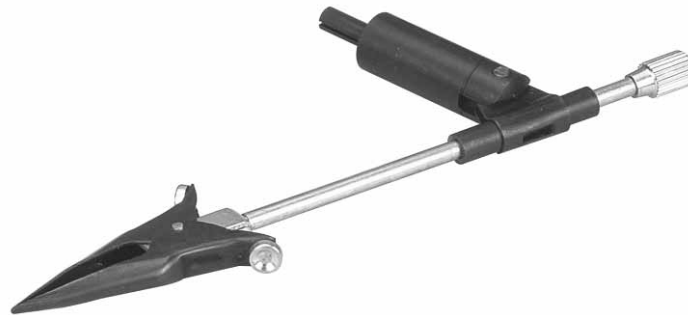

(Fig.4)

Photo adapter SY10

- Attaches to the top of the trinocular tube, allowing any SLR camera to be connected to the microscope for imaging purposes.
- The SY10 adapter for the selected camera has to be screwed into the adapter before connecting to the camera. This SY10 adapter can be obtained from any camera store in your area.
- Can only be used with the SMZ-161T.

C-mount or CS-mount

- Attaches to the top of the trinocular tube, allowing any CCD camera or imaging device to be connected to the microscope.
Select either the C-mount or CS-mount according to the CCD camera to be used.
- Can only be used with the SMZ-161T.

Improved industrial boom stands

- With new slot / groove design for better locking of microscope.
- Grub screw locks into slot / groove, stopping tilt. Microscope is positioned vertical to base with no slant
- Add position for hand-carrying around four sides
- Newly design stands can be used in wide-range of our SMZ series microscopes which allows observing larger viewing samples
- Only one H3 Allen key is necessary for adjusting the boom stand.
- Aluminum support collar with elastic plastic gasket to protect and avoid scratches on the column.

5. CLEANING AND CARING FOR THE MICROSCOPE

To keep the microscope in good working order, avoid **dust and water**. If any dust or water happens to get into the microscope, fungus will grow, damaging the microscope. Please note that once fungus has grown, even after cleaning, the problem may reoccur.

Grease stains and **fingerprints** affect image quality; avoid allowing fingers to come into contact with the surface of optical components.

5.1 Protection against Dust

If the instrument is not to be used for a long period of time, cover it with the dust cover provided. Never leave the eyepiece tube exposed. Either leave the eyepiece in the tube (recommended if the microscope is frequently used) or cover it with wrapping paper or a covering cap. Eyepieces and other optical components that will not be used for a relatively long period of time should be stored in a dry cardboard box, preferably with a desiccating agent added, to shield against dust and moisture.

5.2 Protection against Water and Moisture

The instrument should be kept away from all water sources, including pipes and sinks. Humidity in the room where the instrument located should be kept as low as possible (relative humidity should be kept below 70%). It is recommended that optical components be kept in a dry box when not in use, preferably with a desiccating agent added. The use of dehumidifier and/or 24-hour air conditioning is highly recommended if the surrounding area is humid.

5.3 Cleaning

5.3.1 If dust is found on the optical surface, remove by using an air blower or compressed air.

5.3.2 For fingerprint, grease stains or dust which cannot be removed using air, two possible methods are recommended:

- Breathe lightly on the glass surface and wipe with a clean piece of cloth, lens paper or cotton swab. Please note that small cotton fibers may remain on the surface of the lens if a cotton swab is used.
- Use a cotton swab or lens paper dipped in a small amount of pure alcohol and clean the lens surface carefully. No other aggressive solvents should be used.

Under no circumstances should users clean any lens surface with a dry cotton swab, dry cloth or dry lens paper as this will scratch the lens surface causing irreparable damage. Water is not recommended for cleaning lenses as it will leave water stains on the lens surface, possibly leading to fungus growth and causing irreparable damage.

5.4 Moving the Microscope

- 5.4.1 The microscope should be moved around as little as possible.
- 5.4.2 If it is necessary to move the microscope, users should ensure that the eyepieces are firmly secured in the eyepiece tubes, the microscope firmly secured to the vertical post and the support collar firmly secured before moving.
- 5.4.3 When moving the microscope, use both hands, one hand holding the bottom of the stand and the other hand holding the top of the vertical post of the head holder of the microscope.
- 5.4.4 The microscope should always be kept upright while moving.

5.5 Electrical Parts of the Microscope

- 5.5.1 Before plugging the power cord into the power supply, make sure that the supply voltage matches the operation voltage of the equipment.
- 5.5.2 Turn the equipment off before plugging the power cord into the power supply.
- 5.5.3 It is recommended that users turn down the illumination before turning off the equipment.
- 5.5.4 Do not turn the power on again immediately after it has been turned off as this will shorten the life span of the light bulb and may cause damage to the electrical system.
- 5.5.5 Users should observe all local safety regulations. While the equipment is CE safety approved, users are expected to use the equipment in a safe and responsible manner.

APPENDIX 1: SMZ-161 SPECIFICATIONS

Model	SMZ-161 B	SMZ-161 T
Optical system	Greenough	
Binocular head Observation angle	45°	
Magnification rang (standard)	0.75X--4.5X	
Zoom ratio	1:6	
Eyepiece	WF10X (Ø20) / eyepiece tube adjustable N-WF 15X (Ø16), 20X (Ø13) for optional with RoHS lens	
Interpupillary adjustment	50mm-75mm	
Height of eye point	367mm	
Working distance(standard)	110mm	
Adapters		0.5X, 0.65X, 1X adapters available
Auxiliary ESD objectives	0.3X [WD = 301 mm] 0.5X [WD = 191.8 mm] 0.63X [WD = 142.7 mm] 0.75X [WD = 128.6 mm] 1.5X [WD = 56.3 mm] 2.0X [WD = 38.6 mm]	
Max. working distance (with 0.3X auxiliary objective)	301mm	
Weight	3.5kg (head with 1.0kg)	3.7kg (head with 1.2kg)
Optional illuminator	Ring LED light / fluorescent ring illuminator / cold light source	
Stand option	<ul style="list-style-type: none"> ● Plain stand ● Compact R2LED stand with 3W LED ● Compact R2GG stand with 12/10W halogen incident and 12/20W halogen transmitted light ● Optionally several boom stands for industrial use are available 	

APPENDIX 2: SMZ-161 OPTICAL DATA

Eyepiece	Mag.(X)	Standard Objectives		Auxiliary Objectives											
		WD110mm		0.3X		0.5X		0.63X		0.75X		1.5X		2X	
		Mag. (X)	FD (mm)	Mag. (X)	FD (mm)	Mag. (X)	FD (mm)	Mag. (X)	FD (mm)	Mag. (X)	FD (mm)	Mag. (X)	FD (mm)	Mag. (X)	FD (mm)
10X/20*	0.75	7.5	26.67	2.25	88.89	3.75	53.33	4.725	42.33	5.625	35.56	11.25	17.78	15	13.33
	1	10	20	3	66.67	5	40	6.3	31.75	7.5	26.67	15	13.33	20	10
	2	20	10	6	33.33	10	20	12.6	15.87	15	13.33	30	6.67	40	5
	3	30	6.67	9	22.22	15	13.33	18.9	10.58	22.5	8.89	45	4.44	60	3.33
	4	40	5	12	16.67	20	10	25.2	7.94	30	6.67	60	3.33	80	2.5
10X/23	4.5	45	4.44	13.5	14.81	22.5	8.89	28.35	7.05	33.75	5.93	67.5	2.96	90	2.22
	0.75	7.5	30.67	2.25	102.22	3.75	61.33	4.725	48.68	5.625	40.89	11.25	20.44	15	15.33
	1	10	23	3	76.67	5	46	6.3	36.51	7.5	30.67	15	15.33	20	11.5
	2	20	11.5	6	38.33	10	23	12.6	18.25	15	15.33	30	7.67	40	5.75
	3	30	7.67	9	25.56	15	15.33	18.9	12.17	22.5	10.22	45	5.11	60	3.83
15X/16*	4	40	5.75	12	19.17	20	11.5	25.2	9.13	30	7.67	60	3.83	80	2.88
	4.5	45	5.11	13.5	17.04	22.5	10.22	28.35	8.11	33.75	6.81	67.5	3.41	90	2.56
	0.75	11.25	21.33	3.38	71.11	5.63	42.67	7.09	33.86	8.44	28.44	16.88	14.22	22.5	10.67
	1	15	16	4.5	53.33	7.5	32	9.45	25.4	11.25	21.33	22.5	10.67	30	8
	2	30	8	9	26.67	15	16	18.9	12.7	22.5	10.67	45	5.33	60	4
20X/12*	3	45	5.33	13.5	17.78	22.5	10.67	28.35	8.47	33.75	7.11	67.5	3.56	90	2.67
	4	60	4	18	13.33	30	8	37.8	6.35	45	5.33	90	2.67	120	2
	4.5	67.5	3.56	20.25	11.85	33.75	7.11	42.52	5.64	50.63	4.74	101.25	2.37	135	1.78
	0.75	15	16	4.5	53.33	7.5	32	9.45	25.4	11.25	21.33	22.5	10.67	30	8
	1	20	12	6	40	10	24	12.6	19.05	15	16	30	8	40	6
20X/13	2	40	6	12	20	20	12	25.2	9.52	30	8	60	4	80	3
	3	60	4	18	13.33	30	8	37.8	6.35	45	5.33	90	2.67	120	2
	4	80	3	24	10	40	6	50.4	4.76	60	4	120	2	160	1.5
	4.5	90	2.67	27	8.89	45	5.33	56.7	4.23	67.5	3.56	135	1.78	180	1.33
	0.75	15	17.33	4.5	57.78	7.5	34.67	9.45	27.51	11.25	23.11	22.5	11.56	30	8.67
20X/13	1	20	13	6	43.33	10	26	12.6	20.63	15	17.33	30	8.67	40	6.5
	2	40	6.5	12	21.67	20	13	25.2	10.32	30	8.67	60	4.33	80	3.25
	3	60	4.33	18	14.44	30	8.67	37.8	6.88	45	5.78	90	2.89	120	2.17
	4	80	3.25	24	10.83	40	6.5	50.4	5.16	60	4.33	120	2.17	160	1.63
	4.5	90	2.89	27	9.63	45	5.78	56.7	4.59	67.5	3.85	135	1.93	180	1.44

Note: "WD" = Working Distance "Mag." = Magnification "FD" = Field Diameter

Note: * - High eyepoint eyepiece

Motic[®]

NO.: 1300901108871

Motic Incorporation Ltd. (Hong Kong)

Rm 2907-8, Windsor House, 311 Gloucester Road, Causeway Bay, Hong Kong Tel: 852-2837 0888 Fax: 852-2882 2792

Motic Instruments Inc. (Canada)

130-4611 Viking Way, Richmond, B.C., V6V 2K9 Canada Tel: 1-877-977 4717 Fax: 1-604-303 9043

Motic Deutschland GmbH (Germany)

Christian-Kremp-Strasse 11 D-35578 Wetzlar, Germany Tel: 49-6441-210 010 Fax: 49-6441-210 0122

Motic Spain, S.L. (Spain)

Polígono Industrial Les Corts, Camí del Mig, 112 08349 Cabrera de Mar, Barcelona Spain Tel: 34-93-756 6286
Fax: 34-93-756 6287

Website: <http://www.motic.com>

E-mail: info@speedfair.com

Motic China Group., Ltd. (China)

Motic Building, Torch Hi-Tech Industrial, Development Zone, Xiamen P.R.C. Tel: 86-0592-562 7866 Fax: 86-0592-562 7855

© 2007-2012 Motic China Group Co., Ltd. All rights reserved. Motic is a registered trademark and service mark of Motic China Group Co., Ltd. Microsoft Windows logo is a registered trademark of Microsoft Corporation. All other trademarks are the property of their respective owners.

Design Change: The manufacturer reserves the right to make changes in instrument design in accordance with scientific and mechanical progress, without notice and without obligation.